

DE	Gebrauchsanleitung / Montageanleitung	2
FR	Mode d'emploi / Instructions de montage	2
EN	Instructions for use / assembly instructions	3
IT	Istruzioni per l'uso / Istruzioni per Installazione	3
ES	Modo de empleo / Instrucciones de montaje	4
NL	Gebruiksaanwijzing / Handleiding	4
DK	Brugsanvisning / Monteringsvejledning	5
PT	Instruções para uso / Manual de Instalação	5
PL	Instrukcja obsługi / Instrukcja montażu	6
CS	Návod k použití / Montážní návod	6
SK	Návod na použitie / Montážny návod	7
ZH	用户手册 / 组装说明	7
RU	Руководство пользователя / Инструкция по монтажу	8
FI	Käyttöohje / Asennusohje	8
SV	Bruksanvisning / Monteringsanvisning	9
LT	Vartotojo instrukcija / Montavimo instrukcijos	9
HR	Upute za uporabu / Uputstva za instalaciju	10
TR	Kullanım kılavuzu / Montaj kılavuzu	10
RO	Manual de utilizare / Instrucțiuni de montare	11
EL	Οδηγίες χρήσης / Οδηγία συναρμολόγησης	11
SL	Navodilo za uporabo / Navodila za montažo	12
ET	Kasutusjuhend / Paigaldusjuhend	12
LV	Lietošanas pamācība / Montāžas instrukcija	13
SR	Uputstvo za upotrebu / Uputstvo za montažu	13
NO	Bruksanvisning / Montasjeveiledning	14
BG	Инструкция за употреба / Ръководство за монтаж	14
SQ	Udhëzuesi i përdorimit / Udhëzime rreth montimit	15
AR	دليل الاستخدام / تعليمات التجميع	15
HU	Használati útmutató / Szerelési útmutató	16

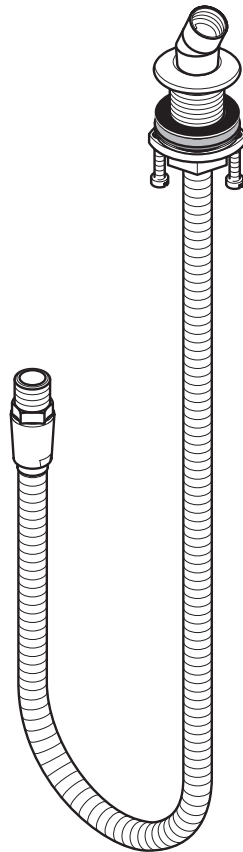

28307000 / 28307330



Sicherheitshinweise

- △ Bei der Montage müssen zur Vermeidung von Quetsch- und Schnittverletzungen Handschuhe getragen werden.
- △ Das Produkt darf nur zu Bade-, Hygiene- und Körperreinigungszwecken eingesetzt werden.
- △ Große Druckunterschiede zwischen den Kalt- und Warmwasseranschlüssen müssen ausgeglichen werden.

Montagehinweise

- Vor der Montage muss das Produkt auf Transportschäden untersucht werden. Nach dem Einbau werden keine Transport- oder Oberflächenschäden anerkannt.
- Die Leitungen und die Armatur müssen nach den gültigen Normen montiert, gespült und geprüft werden.
- Die in den Ländern jeweils gültigen Installationsrichtlinien sind einzuhalten.
- Das Wannrandset muss so eingebaut werden, dass sämtliche Bauteile jederzeit zugänglich sind und bei Bedarf ausgetauscht werden können. Damit durch die Schlauchdurchführung eintretendes Wasser und auch eine eventuelle Undichtigkeit des Brauseschlauches unter der Wanne keine Schäden verursachen können, muss dieser Bereich gegen Wasser geschützt sein.
- Das Produkt ist ausschließlich für Trinkwasser konzipiert!

Symbolerklärung



Kein essigsäurehaltiges Silikon verwenden!



Maße (siehe Seite 17)



Serviceteile (siehe Seite 19)

Sonderzubehör

(nicht im Lieferumfang enthalten)



• Securflex Box #28389000 (siehe Seite 19)



• Rückflussverhindererpatrone #94146000 (siehe Seite 19)



Reinigung (siehe Seite 20)



Wartung

Es muss einmal jährlich eine Dichtheitsprüfung vorgenommen werden.

Montage

(siehe Seite 18)



Consignes de sécurité

- △ Lors du montage, porter des gants de protection pour éviter toute blessure par écrasement ou coupure.
- △ Le produit ne doit servir qu'à se laver et à assurer l'hygiène corporelle.
- △ Il est conseillé d'équilibrer les pressions de l'eau chaude et froide.

Instructions pour le montage

- Avant son montage, s'assurer que le produit n'a subi aucun dommage pendant le transport. Après le montage, tout dommage de transport ou de surface ne pourra pas être reconnu.
- Les conduites et la robinetterie doivent être montés, rincés et contrôlés selon les normes en vigueur.
- Les directives d'installation en vigueur dans le pays concerné doivent être respectées.
- Le support pour montage sur rebord de baignoire doit être posé de manière à ce que tous les éléments soient accessibles et puissent être échangés en cas de besoin. Cette zone doit être protégée contre l'infiltration d'eau due au passage de conduite et d'un manque éventuel d'étanchéité du tuyau de la douchette sous la baignoire.
- Le produit est exclusivement conçu pour de l'eau potable!

Description du symbole



Ne pas utiliser de silicone contenant de l'acide acétique!



Dimensions (voir pages 17)



Pièces détachées (voir pages 19)

Accessoires en option

(ne fait pas partie de la fourniture)



• Securflex Box #28389000 (voir pages 19)



• dispositif anti retour #94146000 (voir pages 19)



Nettoyage (voir pages 20)



Entretien

Faites une fois une épreuve de la fuite par année.

Montage

(voir pages 18)





Safety Notes

- △ Gloves should be worn during installation to prevent crushing and cutting injuries.
- △ The product may only be used for bathing, hygienic and body cleaning purposes.
- △ The hot and cold supplies must be of equal pressures.

Installation Instructions

- Prior to installation, inspect the product for transport damages. After it has been installed, no transport or surface damage will be honoured.
- The pipes and the fixture must be installed, flushed and tested as per the applicable standards.
- The plumbing codes applicable in the respective countries must be observed.
- When installing the bath fitting set, it must be guaranteed that all the parts are easily accessible and can be removed if necessary. To avoid damage by water penetrating through the hose bushing or through any defects in the shower hose under the tub, this area must be protected against leaking water.
- The product is exclusively designed for drinking water!



Symbol description

 Do not use silicone containing acetic acid!

 **Dimensions** (see page 17)

 **Spare parts** (see page 19)

Special accessories (order as an extra)

-  Secuflex Box #28389000 (see page 19)
-  back flow preventor cartridge #94146000 (see page 19)

 **Cleaning** (see page 20)

 **Maintenance**

Do a leak test once a year.

Indicazioni sulla sicurezza

- △ Durante il montaggio, per evitare ferite da schiacciamento e da taglio bisogna indossare guanti protettivi.
- △ Il prodotto deve essere utilizzato esclusivamente per fare il bagno e per l'igiene del corpo.
- △ Attenzione! Compensare le differenze di pressione tra i collegamenti dell'acqua fredda e dell'acqua calda.

Istruzioni per il montaggio

- Prima del montaggio è necessario controllare che non ci siano stati danni durante il trasporto. Una volta eseguito il montaggio, non verranno riconosciuti eventuali danni di trasporto o delle superfici.
- Montare, lavare e controllare tubature e rubinetteria rispettando le norme correnti.
- Vanno rispettate le direttive di installazione nazionali vigenti nel rispettivo paese.
- L'installazione del set bordo vasca deve garantire la possibilità che ogni parte venga facilmente raggiunta e se necessario sostituita. Per evitare danni causati dall'infiltrazione di acqua attraverso il passaggio del tubo ed eventualmente da perdite del tubo della doccia sotto la vasca, la zona sotto la vasca deve essere protetta.
- Il prodotto è concepito esclusivamente per acqua potabile!

Descrizione simbolo

 Non utilizzare silicone contenente acido acetico!

 **Ingombri** (vedi pagg. 17)

 **Parti di ricambio** (vedi pagg. 19)

Accessori speciali

(non contenuto nel volume di fornitura)

-  Secuflex Box #28389000 (vedi pagg. 19)
-  valvola antiriflusso #94146000 (vedi pagg. 19)

 **Pulitura** (vedi pagg. 20)

 **Manutenzione**

Comprovare annualmente l'estanqueidad della rubinetteria.

Assembly
(see page 18) 

Montaggio
(vedi pagg. 18)  **3**



Indicaciones de seguridad

- △ Durante el montaje deben utilizarse guantes para evitar heridas por aplastamiento o corte.
- △ El producto solo debe ser utilizado para fines de baño, higiene y limpieza corporal.
- △ Grandes diferencias de presión en servicio entre agua fría y agua caliente deben equilibrarse.

Indicaciones para el montaje

- Antes del montaje se debe examinar el producto contra daños de transporte. Después de la instalación no se reconoce ningún daño de transporte o de superficie.
- Los conductos y la grifería deben montarse, lavarse y comprobarse según las normas vigentes.
- Es obligatorio el cumplimiento de las directrices de instalación vigentes en el país respectivo.
- La parte empotrada de la grifería debe ser instalada de tal forma que todos los componentes sean accesibles e intercambiables en cada momento. Para que el agua que penetre por el paso del tubo, así como en caso de fuga en el tubo de la ducha, no pueda causar daños debajo de la bañera es necesario proteger esa zona contra el agua.
- El producto ha sido concebido exclusivamente para agua potable.

Descripción de símbolos



No utilizar silicona que contiene ácido acético!



Dimensiones (ver página 17)



Repuestos (ver página 19)

Opcional (no incluido en el suministro)



• Secuflex Box #28389000 (ver página 19)



• cartucho anti-retorno #94146000 (ver página 19)



Limpiar (ver página 20)



Mantenimiento

Comprobar la estanqueidad de la grifería anual-mente.



Veiligheidsinstructies

- △ Bij de montage moeten ter voorkoming van knel- en snijwonden handschoenen worden gedragen.
- △ Het product mag alleen voor het wassen, hygiënische doeleinden en voor de lichaamsreiniging worden gebruikt.
- △ Grote drukverschillen tussen de koud- en warmwater-toevoer dienen vermeden te worden.

Montage-instructies

- Vóór de montage moet het product gecontroleerd worden op transportschade. Na de inbouw wordt geen transport- of oppervlakteschade meer aanvaard.
- De leidingen en armaturen moeten gemonteerd, gespoeld en gecontroleerd worden volgens de geldige normen.
- De in de overeenkomstige landen geldende installatierichtlijnen moeten nageleefd worden.
- De badrandset moet zodanig worden geplaatst, dat alle onderdelen altijd toegankelijk zijn en indien nodig vervangen kunnen worden. Om te vermijden dat via de slangdoorvoer binnenkomend water en eventuele ondichtheid van de sproeislang schade veroorzaken onder het bad, dient die ruimte beschermd te zijn tegen water.
- Het product is uitsluitend ontworpen voor drinkwater!

Symboolbeschrijving



Gebruik geen zuurhoudende silicone!



Maten (zie blz. 17)



Service onderdelen (zie blz. 19)

Toebehoren

(behoort niet tot het leveringspakket)



• Secuflex Box #28389000 (zie blz. 19)



• Terugslagkleppen #94146000 (zie blz. 19)



Reinigen (zie blz. 20)



Onderhoud

Eénmaal per jaar moet men deze ruimte op dichtheid testen.



Sikkerhedsanvisninger

- △ Ved monteringen skal der bruges handsker for at undgå kvæstelser og snitsår.
- △ Produktet må kun bruges til bade-, hygiejne og kropssrengøringsformål.
- △ Større trykforskelle mellem koldt og varmt vand bør udjævnes.

Monteringsanvisninger

- Før monteringen skal produktet kontrolleres for transportskader. Efter monteringen godkendes transportskader eller skader på overfladen ikke længere.
- Ledningerne og armaturerne skal monteres, skylles og kontrolleres iht. de gældende standarder.
- Installationsbestemmelserne, der gælder i det enkelte land, skal overholdes.
- Indbygningsarmaturet til karrand skal installeres således, at samtlige indbygningsdele til hver en tid er tilgængelige og ved behov kan udskiftes. For at vand, som trænger ind gennem slangegennemføringen og eventuelle lækager af bruserslangen, ikke kan forårsage skader under karret, skal dette område være beskyttet mod vand.
- Produktet er udelukkende beregnet til drikkevand!

Symbolbeskrivelse

 Der må ikke benyttes eddikesyreholdig silikone!

 **Målene** (se s. 17)

 **Reservedele** (se s. 19)

Specialtilbehør (ikke med i leveringsomfang)

- Secuflex-boks #28389000 (se s. 19)
- Kontraventil #94146000 (se s. 19)

 **Rengøring** (se s. 20)

 **Service**

Der bør årligt foretages en tæthedsprøve.

Avisos de segurança

- △ Durante a montagem devem ser utilizadas luvas de proteção, de modo a evitar ferimentos resultantes de entalamentos e de cortes.
- △ O produto só pode ser utilizado para fins de higiene pessoal.
- △ Grandes diferenças entre as pressões das águas quente e fria devem ser compensadas.

Avisos de montagem

- Antes da montagem deve-se controlar o produto relativamente a danos de transporte. Após a montagem não são aceites quaisquer danos de transporte ou de superfície.
- As tubagens e a torneira têm que ser montadas, enxaguadas e verificadas de acordo com as normas em vigor.
- A prescrições de instalação válidas nos respetivos países devem ser respeitadas.
- Ao instalar o conjunto da misturadora de banheira, deve-se garantir que qualquer dos seus componentes deve ficar acessível e passível de remoção. Para evitar danos provocados pela eventual passagem de água e por eventuais fugas pelo do tubo flexível, o chão debaixo da banheira deve ser impermeabilizado e protegido contra eventuais fugas de água.
- Este produto foi única e exclusivamente concebido para água potável!

Descrição do símbolo

 Não utilizar silicone que contenha ácido acético!

 **Medidas** (ver página 17)

 **Peças de substituição** (ver página 19)

Acessórios especiais

(não incluído no volume de fornecimento)

- Secuflex Box #28389000 (ver página 19)
- Cartucho anti-retorno #94146000 (ver página 19)

 **Limpeza** (ver página 20)

 **Manutenção**

Faça um ensaio de fugas uma vez por ano.

Montering

(se s. 18) 

Montagem

(ver página 18) 

**Wskazówki bezpieczeństwa**

- △ Aby uniknąć zranień na skutek zgniecenia lub przecięcia, podczas montażu należy nosić rękawice ochronne.
- △ Produkt może być używany tylko do kąpieli, higieny i czyszczenia ciała.
- △ Znaczne różnice ciśnień na dopływach ciepłej i zimnej wody muszą zostać wyrównane.

Wskazówki montażowe

- Przed montażem należy skontrolować produkt pod kątem szkód transportowych. Po montażu nie widać żadnych szkód transportowych ani szkód na powierzchni.
- Przewody i armatura muszą być montowane, płukane i kontrolowane według obowiązujących norm.
- Należy przestrzegać wytycznych instalacyjnych obowiązujących w danym kraju.
- Zestaw krawędziowy wanny musi być zamontowany w taki sposób, by wszystkie podzespoły były dostępne w każdym czasie i w razie potrzeby można je było wymienić. W celu uniknięcia szkód powodowanych przez wnikającą pod wannę wodę z przepustu węża i z racji ewentualnej nieszczelności węża prysznicowego, obszar należy zabezpieczyć przed przedostawaniem się wody.
- Produkt przeznaczony wyłącznie do wody pitnej!

Opis symbolu

Nie stosować silikonów zawierających kwas octowy!



Wymiary (patrz strona 17)



Części serwisowe (patrz strona 19)

Wyposażenie specjalne

(Nie jest częścią dostawy)



• Secuflex Box #28389000 (patrz strona 19)



• Wkład uniemożliwiający zawrót #94146000 (patrz strona 19)



Czyszczenie (patrz strona 20)



Konserwacja

Raz w roku należy podjąć kontrolę szczelności.

**Bezpečnostní pokyny**

- △ Pro zabránění řezným zraněním a pohmožděním je nutné při montáži nosit rukavice.
- △ Produkt smí být používán pouze ke koupání a za účelem tělesné hygieny.
- △ Je nutné vyrovnat velké rozdíly tlaku mezi přípoji studené a teplé vody.

Pokyny k montáži

- Před montáží je třeba produkt zkontrolovat, zda nebyl při transportu poškozen. Po zabudování nebudou uznány žádné škody způsobené transportem nebo poškození povrchu.
- Vedení a armatura musí být namontovány, propláchnuty a otestovány podle platných norem.
- Je třeba dodržovat montážní pravidla platné v dané zemi.
- Sada okrajů vany musí být namontována tak, aby byl možný vždy přístup ke všem dílům a tyto mohly být dle potřeby vyměněny. Aby voda přiváděná hadicovým provedením nemohla pod vanou způsobit žádnou škodu, je třeba tento prostor zajistit proti prosakující vodě. Aby nedošlo k poškození prostoru pod vanou z důvodu vytékání vody z vedení hadice nebo případných netěsností sprchové hadice, je nezbytné tento prostor proti vodě chránit.
- Výrobky Hansgrohe jsou vhodné pro přímý kontakt s pitnou vodou.

Popis symbolů

Nepoužívat silikon s obsahem kyseliny octové!



Rozměry (viz strana 17)



Servisní díly (viz strana 19)

Zvláštní příslušenství

(není součástí dodávky)



• Secuflex Box #28389000 (viz strana 19)



• Patrona zabraňující zpětnému proudění #94146000 (viz strana 19)



Čištění (viz strana 20)



Údržba

Je třeba jednou ročně provést zkoušku těsnosti.

Montaż

(patrz strona 18) 

Montáž

(viz strana 18) 



Bezpečnostné pokyny

- △ Pri montáži musíte nosiť rukavice, aby ste predišli pomliaždeninám a rezným poraneniam.
- △ Produkt sa smie používať len na kúpanie a telesnú hygienu.
- △ Veľké rozdiely v tlaku medzi prípojkami studenej a teplej vody musia byť vyrovnané.

Pokyny pre montáž

- Pred montážou musíte produkt skontrolovať, či nebol počas transportu poškodený. Po zabudovaní nebudú uznané žiadne škody spôsobené transportom alebo poškodenia povrchu.
- Ledningarna och blandaren måste monteras, spolagsigenom och kontrolleras enligt de gällande normerna.
- Je potrebné dodržiavať smernice o inštalácii, ktoré sú práve teraz platné v krajinách.
- Sada okrajov vane sa musí namontovať tak, aby bol vždy možný prístup ku všetkým dielom, a aby sa tieto dali vždy podľa potreby vymeniť. Aby voda vnikajúca cez hadicovú priechodku a ani prípadná netesnosť hadice sprchy nemohla pod vaňou spôsobiť žiadne škody, musí byť tento priestor chránený proti vode.
- Výrobok je koncipovaný výhradne pre pitnú vodu!

Popis symbolov

 Nepoužívať silikón s obsahom kyseliny octovej!

 **Rozmery** (viď strana 17)

 **Servisné diely** (viď strana 19)

Zvláštne prísľušenstvo

(nie je súčasťou dodávky)

- Secuflex Box #28389000 (viď strana 19)
- Patróna zabraňujúca spätnému prúdeniu #94146000 (viď strana 19)

 **Čistenie** (viď strana 20)

 **Údržba**

Raz ročne je potrebné vykonať skúšku tesnosti.

安全技巧

- △ 装配时为避免挤压和切割受伤，必须戴上手套。
- △ 本产品只允许作为洗浴、卫生和洁身之用。
- △ 冷热水管间过大的压力差必须予以平衡。

安装提示

- 安装前必须检查产品是否受到运输损害。安装后将不认可运输损害或表面损伤。
- 管道和阀门必须根据通用标准进行安装、冲洗和检查。
- 请遵守当地国家现行的安装规定。
- 所安装的面盆龙头必须使得所有构件随时可接触到并且在需要时可以进行更换。为确保穿透软管套管的水不会造成损失，必须防止该区域漏水。
- 该产品专为饮用水设计！

符号说明

 请勿使用含有乙酸的硅胶！

 **大小** (参见第页 17)

 **备用零件** (参见第页 19)

选装附件 (不在供货范围内)

- Secuflex盒子 #28389000 (参见第页 19)
- 止回阀滤芯 #94146000 (参见第页 19)

 **清洗** (参见第页 20)

 **保养**

每年必须进行一次密封性检查。



Указания по технике безопасности

- △ Во время монтажа следует надеть перчатки во избежание прищемления и порезов.
- △ Изделие разрешается использовать только в гигиенических целях: для принятия ванны и личной гигиены.
- △ донного клапа. Перед установкой смесителя необходимо регулировочными кранами выровнять давление холодной и горячей воды при помощи вентилей регулирующих подачу воды в квартиру.

Указания по монтажу

- Перед монтажом следует проверить изделие на предмет повреждений при перевозке. После монтажа претензии о возмещении ущерба за повреждения при перевозке или повреждения поверхностей не принимаются.
- Трубы и арматура должны быть установлены, промыты и проверены в соответствии с действующими нормами.
- Необходимо соблюдать требования по монтажу, действующие в соответствующих странах.
- При установке комплекта для ванн следует обеспечить доступ ко всем комплектующим и возможность их замены по мере необходимости. Во избежание ущерба при попадании воды под ванну в ходе прокладывания душевого шланга следует обеспечить защиту этого участка от протечек.
- Изделие предназначено исключительно для питьевой воды!

Описание символов



Не применяйте силикон, содержащий уксусную кислоту.



Размеры (см. стр. 17)



Комплект (см. стр. 19)

Специальные принадлежности

(не включено в объем поставки!)



• Блок Secuflex #28389000 (см. стр. 19)



• Патрон клапана обратного течения #94146000 (см. стр. 19)



Очистка (см. стр. 20)



Техническое обслуживание

Один раз в год следует проводить проверку на предмет герметичности.

Монтаж

(см. стр. 18)



Turvallisuusohjeet

- △ Asennuksessa on käytettävä käsineitä puristumien ja viiltojen aiheuttamien tapaturmien estämiseksi.
- △ Tuotetta saa käyttää ainoastaan kylpy-, hygienia- ja puhdistustarkoituksiin.
- △ Suuret paine-erot kylmä- ja kuumavesiliitäntöjen välillä on tasattava.

Asennusohjeet

- Ennen asennusta on tarkastettava tuotteen mahdolliset kuljetusvahingot. Asennuksen jälkeen kuljetus- ja pintavaurioita ei hyväksytä.
- Putket ja hana on asennettava, huuhdeltava ja tarkastettava voimassa olevien standardien mukaisesti.
- Jokaisessa maassa on noudatettava siellä päteviä asennusohjeita.
- Kylpyammeen reunasetti on asennettava siten, että kaikki rakenneosat ovat vapaasti huollettavissa ja tarvittaessa vaihdettavissa. Jotta lenkun läpiviennistä sisään pääsevä vesi ja suihkuletkun mahdollinen epätiiviyys eivät aiheuttaisi vahinkoja ammeen alla, tämä alue on suojattava veden varalta.
- Tuote on suunniteltu käytettäväksi ainoastaan juomaveden kanssa!

Merkin kuvaus



Älä käytä etikkahappopitoista silikonia!



Mitat (katso sivu 17)



Varaosat (katso sivu 19)

Erityisvaruste (ei kuulu toimitukseen)



• Secuflex Box #28389000 (katso sivu 19)



• Paluuvirtauksenestopatruuna #94146000 (katso sivu 19)



Puhdistus (katso sivu 20)



Huolto

Tiiviystarkastus on suoritettava kerran vuodessa.

Asennus

(katso sivu 18)



Säkerhetsanvisningar

- △ Handskar ska bäras under monteringsarbetet så att man kan undvika kläm- och skärskador.
- △ Produkten får bara användas till kroppshygien med bad och dusch.
- △ Stora tryckskillnader mellan anslutningarna för varmt och kallt vatten måste utjämnas.

Monteringsanvisningar

- Det måste undersökas om produkten har transportskador innan den monteras. Efter monteringen accepteras inga transport- eller ytskiktsskador.
- Ledningarna och blandaren måste monteras, spolas igenom och kontrolleras enligt de gällande normerna.
- De installationsriktlinjer som gäller i länderna ska följas.
- Sargmonteringsstatsen måste placeras på sådant sätt att alla delar alltid är tillgängliga och kan bytas ut vid behov. Vatten som kommer in genom slanggenomföringen och även en eventuell otätethet hos duschslangen under karet får inte kunna orsaka skador och därför måste det här området vara skyddat mot vatten.
- Produkten är enbart avsedd för dricksvatten!

Symbolförklaring

 Använd inte silikon som innehåller ättiksyra!

 **Måtten** (se sidan 17)

 **Reservdelar** (se sidan 19)

Specialtillbehör (medföljer ej leveransen)

- Secuflex Box #28389000 (se sidan 19)
- Backventil #94146000 (se sidan 19)

 **Rengöring** (se sidan 20)

 **Skötsel**

Tättheten måste kontrolleras en gång varje år.

Saugumo technikos nurodymai

- △ Apsaugai nuo užspaudimo ir įsijiovimo montavimo metu mūvėkite pirštines.
- △ Gaminys turi būti naudojamas tik maudymuisi, kūno higienai ir švarai palaikyti.
- △ Turi būti išlyginti šalto ir karšto slėgio nelygumai.

Montavimo instrukcija

- Prieš montuojant būtina patikrinti, ar gaminys nebuvo pažeistas transportavimo metu. Sumontavus pretenzijos dėl transportavimo ir paviršiaus pažeidimų nepriimamos.
- Vamzdžiai ir sujungimai turi būti montuojami, plaunami ir tikrinami pagal galiojančias normas.
- Laikykites atitinkamoje šalyje galiojančių direktyvų dėl įrengimo.
- Vonios kraštai turi būti taip įstatomi, kad bet kurioju metu būtų galima prieiti prie bet kurios dalies ir, reikalui esant, ją pakeisti. Kad žarnomis tekantis vanduo ir galimai nesandari dušo žarna po vonia nepridarytų žalos, šių zonų reikia izoliuoti nuo vandens.
- Produktas skirtas tik geriamajam vandeniui!

Simbolio aprašymas



Nenaudokite silikono, kurio sudėtyje yra acto rūgšties!



Išmatavimai (žr. psl. 17)



Atsarginės dalys (žr. psl. 19)



Specialūs priedai (nėra pridedama)



• „Secuflex“ dėžutė #28389000 (žr. psl. 19)



• Grįžtančio vandens blokavimo patronas #94146000 (žr. psl. 19)



Valymas (žr. psl. 20)



Techninis aptarnavimas

Kartą per metus reikia patikrinti sandarumą.





Sigurnosne upute

- Prilikom montaže se radi sprječavanja prignječenja i posjekotina moraju nositi rukavice.
- Proizvod se smije primjenjivati samo za kupanje, tuširanje i osobnu higijenu.
- Velika razlika u pritisku između vruće i hladne vode mora biti izbalansirana.

Upute za montažu

- Prije montaže mora se provjeriti je li proizvod oštećen prilikom transporta. Nakon ugradnje se ne priznaju nikakve reklamacije koje se odnose na površinska i transportna oštećenja.
- Cijevi i armatura moraju biti postavljeni, isprani i testirani prema važećim normama.
- Obvezno se moraju uvažiti propisi o instalacijama koji vrijede u dotičnoj zemlji.
- Svi elementi koji se ugrađuju na rubu kade moraju se tako postaviti da budu u svakom trenutku dostupni i po potrebi lako zamjenjivi. Kako voda koja curi sa ili iz crijeva tuša ne bi mogla prouzročiti štetu ispod kade, navedeno se područje mora zaštititi od vode.
- Proizvod je koncipiran isključivo za pitku vodu!

Opis simbola



Nemojte koristiti silikon koji sadrži octenu kiselinu!



Mjere (pogledaj stranicu 17)



Rezervni dijelovi

(pogledaj stranicu 19)



Posebni pribor (Nije sadržano u isporuci!)



- Secuflex Box #28389000 (pogledaj stranicu 19)



- Patrona nepovratnog ventila #94146000 (pogledaj stranicu 19)



Čišćenje (pogledaj stranicu 20)



Održavanje

Jednom godišnje se mora provjeriti zabrtvljenost.



Güvenlik uyarıları

- Montaj esnasında ezilme ve kesilme gibi yaralanmaları önlemek için eldiven kullanılmalıdır.
- Ürün yalnızca banyo, hijyen ve beden temizliği amaçları doğrultusunda kullanılabilir.
- Sıcak ve soğuk su bağlantıları arasında büyük basınç farklılıkları varsa, bu basınç farklılıklarının dengelenmesi gerekir.

Montaj açıklamaları

- Montaj işleminden önce ürün nakliye hasarları yönünden kontrol edilmelidir. Montaj işleminden sonra nakliye veya yüzey hasarları için sorumluluk üstlenilmemektedir.
- Boruların ve armatürün montajı, yıkanması ve kontrolü geçerli normlara göre yapılmalıdır.
- Ülkelerde geçerli kurulum yönetmeliklerine riayet edilmelidir.
- Tekne kenarı seti, tüm yapı parçaları her zaman ulaşılabilir olacak ve gerektiğinde değiştirilebileceği şekilde monte edilmelidir. Hortumun içinden akan suyun ve fiske hortumundaki olası bir sızıntının teknenin altında herhangi bir hasara yol açmaması için, bu bölge su sızıntısına karşı korunmalıdır.
- Ürün sadece şebeke suyu için tasarlanmıştır!

Simge açıklaması



Asetik asit içeren silikon kullanmayın!



Ölçüleri (bakınız sayfa 17)



Yedek Parçalar (bakınız sayfa 19)



Özel aksesuarlar

(Teslimat kapsamına dahil değildir)



- Secuflex Box #28389000 (bakınız sayfa 19)



- Geri akış önleme kartuşu #94146000 (bakınız sayfa 19)



Temizleme (bakınız sayfa 20)



Bakım

Yılda bir kez sızdırmazlık testinin yapılması gereklidir.

Sastavljanje

(pogledaj stranicu 18) 

Montajı

(bakınız sayfa 18) 



Instrucțiuni de siguranță

- ⚠ La montare utilizați mănuși pentru evitarea contuziunilor și tăierii mâinilor.
- ⚠ Produsul poate fi utilizat doar pentru spălarea, menținerea igienei și curățarea corpului.
- ⚠ Diferențele de presiune mari între alimentarea cu apă rece și apă caldă trebuie echilibrate.

Instrucțiuni de montare

- Înainte de instalare verificați, dacă produsul prezintă deteriorări de transport. După instalare garanția nu acoperă deteriorările de transport și cele de suprafață.
- Conductele și bateriile trebuie montate, spălate și verificate conform normelor în vigoare.
- Respectați reglementările referitoare la instalare valabile în țara respectivă.
- Setul de la marginea căzii trebuie montat în așa fel, ca toate elementele construcționale să fie permanente accesibile pentru a putea fi schimbate la nevoie. Pentru ca apa, care se scurge prin garnitura de trecere a furtunului sau în cazul unei eventuale scurgeri a furtunului de duș să nu producă deteriorări, această zonă trebuie protejată împotriva apei.
- Produsul este destinat exclusiv pentru apă potabilă.

Descrierea simbolurilor



 Nu utilizați silicon cu conținut de acid acetic!

 **Dimensiuni** (vezi pag. 17)

 **Piese de schimb** (vezi pag. 19)

Accesorii opționale

(nu este inclus în setul livrat)

-  • Boxă secuflex #28389000 (vezi pag. 19)
-  • Patron de reținere #94146000 (vezi pag. 19)

 **Curățare** (vezi pag. 20)

 **Întreținere**

Se va efectua o verificare în privința etanșeității o dată pe an!

Υποδειξεις ασφαλειας

- ⚠ Για να αποφύγετε τραυματισμούς κατά τη συναρμολόγηση πρέπει να φοράτε γάντια.
- ⚠ Το προϊόν επιτρέπεται να χρησιμοποιείται μόνο σαν μέσο λουτρού, υγιεινής και καθαρισμού του σώματος.
- ⚠ Οι διαφορές της πίεσης μεταξύ της σύνδεσης κρύου και ζεστού νερού θα πρέπει να αντισταθμίζονται.

Οδηγίες συναρμολόγησης

- Πριν τη συναρμολόγηση πρέπει να εξεταστεί το προϊόν για ζημιές μεταφοράς. Μετά την εγκατάσταση δεν αναγνωρίζονται ζημιές από τη μεταφορά ή επιφανειακές ζημιές.
- Οι σωλήνες και η μπαταρία πρέπει να τοποθετηθούν σύμφωνα με τα ισχύοντα πρότυπα, να τεθούν υπό πίεση και να δοκιμαστούν.
- Θα πρέπει να τηρούνται οι οδηγίες εγκατάστασης που ισχύουν σε κάθε κράτος.
- Το σετ στην άκρη της μπανιέρας πρέπει να εγκαθίσταται έτσι, ώστε όλα τα εξαρτήματα να είναι προσβάσιμα ανά πάσα στιγμή και εφόσον χρειάζεται να μπορούν να αντικαθίστανται. Για να μην μπορεί να προξενήσει ζημιές το νερό που εισέρχεται από το πέρασμα του ελαστικού σωλήνα όπως επίσης μία διαρροή από τον σωλήνα του ντους κάτω από τη μπανιέρα, θα πρέπει η περιοχή αυτή να προστατευθεί κατάλληλα έναντι διαρροής νερού.
- Το προϊόν έχει σχεδιαστεί αποκλειστικά για πόσιμο νερό!



Περιγραφή συμβόλων

 Μην χρησιμοποιείτε σιλικόνη που περιέχει οξικό οξύ!

 **Διαστάσεις** (βλ. Σελίδα 17)

 **Ανταλλακτικά** (βλ. Σελίδα 19)

Ειδικά αξεσουάρ (δεν περιλαμβάνεται στον παραδοτέο εξοπλισμό)

-  • Κουτί Secuflex #28389000 (βλ. Σελίδα 19)
-  • Φύσιγγα παρεμπόδισης επιστροφής #94146000 (βλ. Σελίδα 19)

 **Καθαρισμός** (βλ. Σελίδα 20)

 **Συντήρηση**

Πρέπει να εκτελείται μία φορά το χρόνο ένας έλεγχος στεγανότητας.

Montare
(vezi pag. 18) 

Συναρμολόγηση
(βλ. Σελίδα 18) 

**Varnostna opozorila**

- △ Pri montaži je treba nositi rokavice, da se prepreči poškodbe zaradi zmečkanja ali urezov.
- △ Ta izdelek se sme uporabljati le z namenom umivanja, vzdrževanja higijene in telesne nege.
- △ Velike razlike v tlaku med priključkom za mrzlo in priključkom za toplo vodo je potrebno izravnati.

Navodila za montažo

- Pred montažo je treba izdelek preveriti glede morebitnih transportnih poškodb. Po vgradnji transportne ali površinske poškodbe ne bodo več priznane.
- Cevi in armaturo je treba montirati, izprati in preveriti po veljavnih standardih.
- Upoštevati je treba pravilnike o inštalacijah, ki veljajo v posamezni državi.
- Komplet robov za kad se mora vgraditi tako, da so vsi elementi vedno dosegljivi in se lahko po potrebi zamenjajo. Da voda, ki vstopa skozi uvodnico gibka cevi, ali pa morebiti netesna gibka cev prhe, ne moreta povzročiti škode pod kadjo, je treba to območje zaščititi pred vdorom vode.
- Proizvod je zasnovan izključno za sanitarno vodo!

Opis simbola

Ne smete uporabiti silikona, ki vsebuje ocetno kislino!



Mere (glejte stran 17)



Rezervni deli (glejte stran 19)



Poseben pribor (Ni vključeno)



- Secuflex Box #28389000 (glejte stran 19)



- Patrona protipovratnega ventila #94146000 (glejte stran 19)



Čiščenje (glejte stran 20)



Vzdrževanje

Enkrat na leto je treba izvesti preizkus tesnosti.

**Ohutusjuhised**

- △ Kandke paigaldamisel muljumis- ja löikevigastuste vältimiseks kindaid.
- △ Toodet tohib kasutada ainult pesemis-, hügieeni- ja kehahupahastamisesmärکیدel.
- △ Kui külma ja kuuma vee ühenduste surve on väga erinev, tuleb need tasakaalustada.

Paigaldamisjuhised

- Enne paigaldamist tuleb toodet kontrollida transportikahjustuste osas. Pärast paigaldamist ei tunnustata enam transporti- või pinnakahjustuste kaebuseid.
- Voolikute ja segisti paigaldamisel, loputamisel ja kontrollimisel tuleb lähtuda kehtivatest normatiividest.
- Vastavas riigis kehtivaid paigalduseeskirju tuleb järgida.
- Vanniäärekomplekt tuleb paigaldada nii, et kõigile selle komponentidele pääseks alati ligi ja neid saaks vajadusel asendada. Et vooliku läbiviigust tulev vesi ja dušivooliku võimalik leke ei tekitaks vanni alla kahjustusi, peab see piirkond olema vee eest kaitsitud.
- Toode on ette nähtud eranditult joogivee jaoks!

Sümbolite kirjeldus

Ärge kasutage äädikhapet sisaldavat silikooni!



Mõõtude (vt lk 17)



Varuosad (vt lk 19)

Spetsiaalne lisavarustus

(ei sisaldu komplektis)



- Secuflex-karp #28389000 (vt lk 19)



- Tagasivoolu takistav element #94146000 (vt lk 19)



Puhastamine (vt lk 20)



Hooldus

Kord aastas tuleb teha tiheduse kontroll.

Montaža

(glejte stran 18) 

Paigaldamine

(vt lk 18) 



Drošības norādes

- △ Montāžas laikā, lai izvairītos no saspiedumiem un iegriezumiem, nepieciešams nēsāt cimdus.
- △ Šo produktu drīkst izmantot tikai, lai mazgātos, higiēnai un ķermeņa tīrīšanai.
- △ Jāizlīdzina spiediena atšķirības starp aukstā un karstā ūdens pievadiem.

Norādījumi montāžai

- Pirms montāžas nepieciešams pārbaudīt, vai produktam transportēšanas laikā nav radušies bojājumi. Pēc iebūvēšanas bojājumi, kas radušies transportēšanas laikā, vai virsmas bojājumi netiek atzīti.
- Cauruļvadi un armatūra ir jāuzstāda, jāizskalo un jāpārbauda saskaņā ar spēkā esošajiem standartiem.
- Jāievēro attiecīgās valstīs spēkā esošās montāžas prasības.
- Vannas malām jābūt iebūvētām tā, lai visas būvniecības detaļas vienmēr būtu pieejamas un nomaināmas pēc nepieciešamības. Lai caur uzstādīto cauruli ienākošais ūdens zem vannas nevarētu izraisīt nekādus bojājumus, šī vieta ir jāaizsargā no ūdens noplūdes.
- Izstrādājums ir paredzēts tikai dzeramajam ūdenim!

Sīmbolu nozīme



Neizmantojiet silikonu, kas satur etiķskābi!



Izmērus (skat. lpp. 17)



Rezerves daļas (skat. lpp. 19)

Speciāli aksesuāri

(komplektā netiek piegādāts)



• Secuflex kārba #28389000 (skat. lpp. 19)



• Atpakalplūsmas novēršanas patrona #94146000 (skat. lpp. 19)



Tīrīšana (skat. lpp. 20)



Apkope

Reizi gadā ir jāveic blīvējuma pārbaude.

Sigurnosne napomene

- △ Prilikom montaže se radi sprečavanja prignječenja i posekotina moraju nositi rukavice.
- △ Proizvod sme da se koristi samo za kupanje, tuširanje i ličnu higijenu.
- △ Velika razlika u pritisku između vruće i hladne vode mora biti izbalansirana.

Instrukcije za montažu

- Pre montaže se mora proveriti da li je proizvod oštećen pri transportu. Nakon ugradnje se ne priznaju nikakve reklamacije koje se odnose na površinska i transportna oštećenja.
- Vodovi i armatura moraju biti postavljeni, isprani i testirani prema važećim normama.
- Treba se pridržavati propisa koji u određenim zemljama važe za instalacije.
- Svi elementi koji se ugrađuju na ivici kade moraju se tako postaviti da budu u svakom trenutku dostupni i da se po potrebi mogu zameniti. Da voda koja curi sa ili iz creva tuša ne bi mogla da izazove štetu ispod kade, ta oblast mora da se zaštititi od vode.
- Proizvod je koncipiran isključivo za pijaću vodu!

Opis simbola



Nemojte koristiti silikon koji sadrži sirćetnu kiselinu!



Mere (vidi stranu 17)



Rezervni delovi (vidi stranu 19)

Poseban pribor (Nije sadržano u isporuci)



• Secuflex Box #28389000 (vidi stranu 19)



• Patrona nepovratnog ventila #94146000 (vidi stranu 19)



Čišćenje (vidi stranu 20)



Održavanje

Jednom godišnje se mora proveriti zaptivenost.

**Sikkerhetshenvisninger**

- △ Bruk hansker under montasjen for å unngå klem- og kuttskader.
- △ Produktet skal kun brukes for bade-, hygiene- og kroppshygiene.
- △ Store trykkdifferanser mellom kaldt- og varmtvannstilkoblinger skal utlignes.

Montagehenvisninger

- Før montasjen skal produktet sjekkes for transportskader. Etter monteringen aksepteres ikke noen transport- eller overflateskader.
- Ledningene og armaturen skal monteres, spyles og sjekkes iht. de gyldige normer.
- Gjeldende retningslinjer for rørleggerarbeid i de enkelte land skal følges.
- Settet for karkanten skal bygges inn slik at alle komponenter til enhver tid er lett tilgjengelige og at de kan byttes ut etter behov. Fordi at vannet som lekker gjennom slangegjennomføringer eller fra lekkasjerpå dusjslangen ikke skal forårsake skader under badekaret, skal dette området beskyttes mot lekkasjevann.
- Produktet er utelukkende designet for drikkevann!

Symbolbeskrivelse

Ikke bruk silikon som inneholder eddiksyre!



Mål (se side 17)



Servicedeler (se side 19)



Ekstratilbehør (ikke med i leveransen)



• Secuflex Box #28389000 (se side 19)



• Returløpssperrepatron #94146000 (se side 19)



Rengjøring (se side 20)



Vedlikehold

En gang i året skal det utføres en tetthetskontroll.

**Указания за безопасност**

- △ При монтажа трябва да се носят ръкавици, за да се избегнат наранявания поради притискане или порязване.
- △ Позволено е използването на продукта само за къпане, хигиена и цели на почистване на тялото.
- △ Големите разлики в налягането между изводите за студената и топлата вода трябва да се изравняват.

Указания за монтаж

- Преди монтажа продуктът трябва да се провери за транспортни щети. След монтажа не се признават транспортни или повърхностни щети.
- Тръбопроводите и арматурата трябва да се монтира, промият и проверят в съответствие с валидните норми.
- Трябва да бъдат спазвани валидните в съответните страни предписания за инсталиране.
- Наборът за ръба на ваната трябва да се монтира така, че всички елементи да бъдат достъпни по всяко време и да могат да бъдат сменени при необходимост. За да не се предизвикват повреди под ваната при прекарване на маркучите, а също и евентуална липса на херметичност на маркуча на разпръсквателя, тази област трябва да бъде защитена от пропуски на вода.
- Продуктът е разработен само за питейна вода!

Описание на символите

Не използвайте силикон, съдържащ оцетна киселина!



Размери (вижте стр. 17)



Сервизни части (вижте стр. 19)

Специални принадлежности

(не се съдържа в обема на доставка)



• Кутия Secuflex #28389000 (вижте стр. 19)



• Патрон на предпазителя за обратен поток #94146000 (вижте стр. 19)



Почистване (вижте стр. 20)



Поддръжка

Веднъж годишно трябва да се проверява херметичността.

Montasje

(se side 18)



Монтаж

(вижте стр. 18)





⚠ Udhëzime sigurie

- ⚠ Për të evituar lëndimet e pickimeve ose të prerjeve gjatë procesit të montimit duhet që të vishni doreza.
- ⚠ Produkti duhet të përdoret vetëm qëllimet e banjave, të higjienës dhe të larjes së trupit.
- ⚠ Ndryshimet e mëdha të presionit mes lidhjeve të ujit të ftohtë dhe atij të ngrohtë duhen ekuilibruar.

Udhëzime për montimin

- Përpara montimit duhet që produkti të kontrollohet për dëmtime nga transporti. Pas instalimit nuk do të njihet asnjë dëmtim nga transporti ose dëmtim i sipërfaqes.
- Tubacionet dhe rubinetet duhet që të montohen, të shpëlahen dhe të kontrollohen sipas standardeve në fuqi
- Duhet të respektohen linjat udhëzuese të instalimit, të vlefshme për vendet respektive.
- Komplet i buzës së vaskës duhet montuar në atë mënyrë që të gjitha pjesët e ndërrimit të mund të ndërrohen në rast nevojë. Për të mos shkaktuar rrjedhje të ujit në vijën prirëse të gypit/tubit, dhe për të mos shkaktuar dëme nën vaskë eventualisht si pasojë e mos hermetizimit të gypit/tubit të shpërkatësës, duhet që kjo zonë të mbrohet nga ndikimi i ujit.
- Produkti është projektuar ekskluzivisht për ujë të pijshëm!

Përshkrimi i simbolit



Mos përdorni silikon që në përbërje ka acid acetik.



Përmasat (shih faqen 17)



Pjesët e servisit (shih faqen 19)

Pajisje të posaçme

(nuk përfshihet në vëllimin e furnizimit)



• Kutia Secuflex #28389000 (shih faqen 19)



• Kaseta e penguesit të rrjedhjes në drejtim të kundërt #94146000 (shih faqen 19)



Pastrimi (shih faqen 20)



Mirëmbajtja

Një herë në vit duhet kontrolluar se a rrjedh uji.

⚠ تنبيهات الأمان

- ⚠ يجب ارتداء قفازات لليد أثناء التركيب لتجنب حدوث أخطار الإنحشار أو الجروح.
- ⚠ لا يجب استخدام المنتج إلا في أغراض الاستحمام والأغراض الصحية وأغراض تنظيف الجسم.
- ⚠ يجب أن يكون تيار الماء الساخن والماء البارد متعادلين في الضغط.

تعليمات التركيب

- قبل القيام بعملية التركيب، يجب فحص المنتج للتأكد من خلوه من أية تليفات ناتجة عن النقل. بعد القيام بعملية التركيب، لن يتم الاعتراف بوجود أية تليفات سطحية أو تليفات ناتجة عن عملية النقل.
- يجب تركيب وغسيل واختبار التوصيلات وخلالات المياه طبقاً للمعايير السارية.
- يجب مراعاة القواعد الخاصة بالتركيب وأعمال السباكة وفقاً للوائح الخاصة بكل بلد.
- يجب تركيب مجموعة حواف البانيو بطريقة تسمح بالوصول لجميع قطع الغيار في جميع الأوقات حتى يمكن استبدالها إذا لزم الأمر. حتى لا تحدث أية أضرار نتيجة الماء الداخل عن طريق فتحة الخرطوم وإمكانية تسريب عن طريق خرطوم الدوش أسفل البانيو، يجب حماية هذا النطاق من تسرب الماء.
- المنتج مخصص فقط لماء الشرب!

وصف الرمز

هام! لا تستخدم السليكون الذي يحتوي على أحماض!

أبعاد (راجع صفحة 17)

قطع الغيار (راجع صفحة 19)

ملحقات خاصة (غير مدرج مع المحتويات المسلمة)

• صندوق Secuflex #28389000 (راجع صفحة 19)

• خرطوشة منع إرتداد الماء للخلف #94146000 (راجع صفحة 19)

التنظيف (راجع صفحة 20)

الصيانة

يجب عمل اختبار سنوي على جلب منع التسرب.

Montimi

(shih faqen 18)

التركيب

(راجع صفحة 18)



Biztonsági utasítások

- △ A szerelésnél a zúzódások és vágási sérülések elkerülése érdekében kesztyűt kell viselni.
- △ A terméket csak fürdéshez, mosakodáshoz, és egészségügyi tisztálkodáshoz szabad használni.
- △ A hidegvíz- és a melegvíz-csatlakozások közötti nagy nyomáskülönbséget kikell egyenlíteni!

Szerelési utasítások

- A szerelés előtt ellenőrizni kell, hogy a terméknek nincs-e szállítási sérülése. Beépítés után a szállítási- vagy felületi sérüléseket nem ismerik el.
- A vezetékeket és a csaptelepet az érvényes szabványoknak megfelelően kell felszerelni, öblíteni és ellenőrizni
- Az egyes országokban érvényes installációs irányelveket be kell tartani.
- A kádperem készletet úgy kell beépíteni, hogy minden alkatrész bármikor elérhető legyen, és szükség esetén ki lehessen cserélni. Azért, hogy a tömlőátvezetésen belépő víz és a zuhanytömlő esetleges szivárgása ne okozzon károkat a kád alatt, ezt a területet szivárgó víz ellen védeni kell.
- A terméket kizárólag ivóvízhez tervezték!

Szimbólumok leírása



Ne használjon ecetsavtartalmú szilikon!



Méretet (lásd a oldalon 17)



Tartozékok (lásd a oldalon 19)

Egyéb tartozék

(a szállítási egység nem tartalmazza)



- Secuflex Box #28389000
(lásd a oldalon 19)



- Visszafolyásgátló patron #94146000
(lásd a oldalon 19)



Tisztítás (lásd a oldalon 20)



Karbantartás

Évente egyszer szivárgási ellenőrzést kell végezni.

Szerelés

(lásd a oldalon 18) 

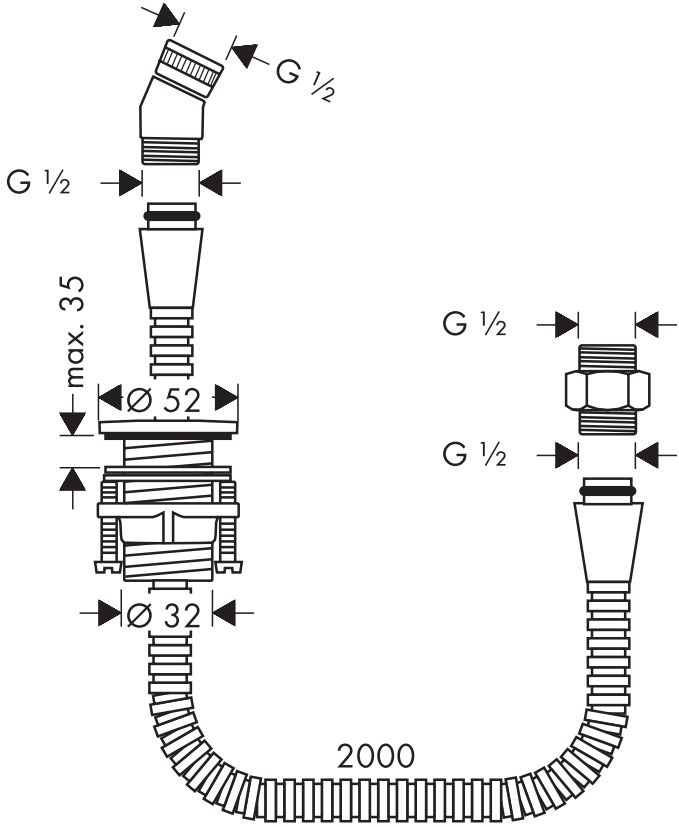

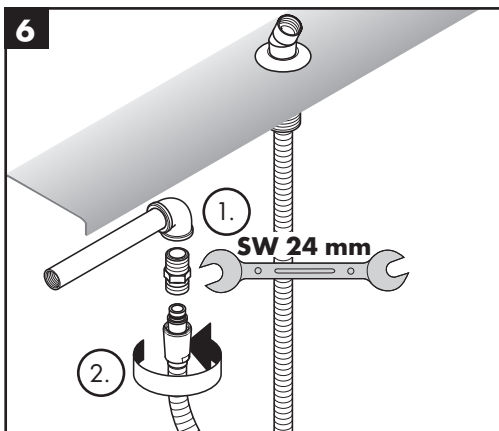
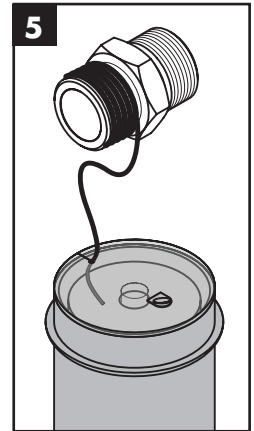
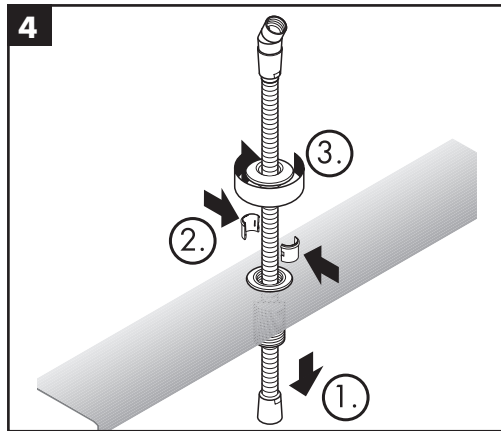
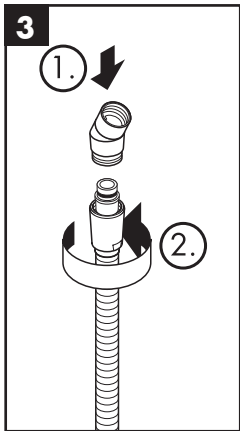
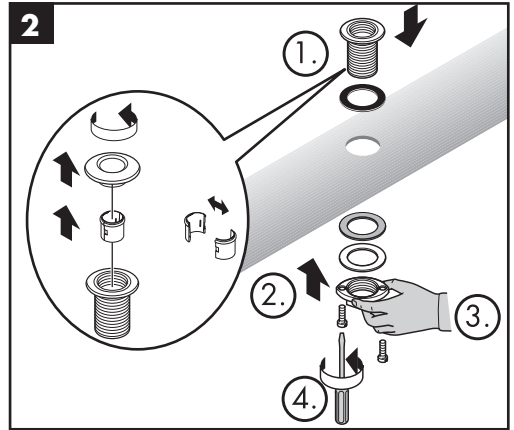
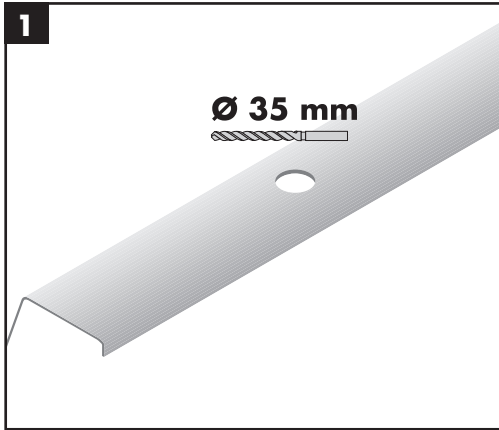

XXX = Colors
 000 = Chrome
 020 = Polished Chrome
 330 = Polished Black Chrome

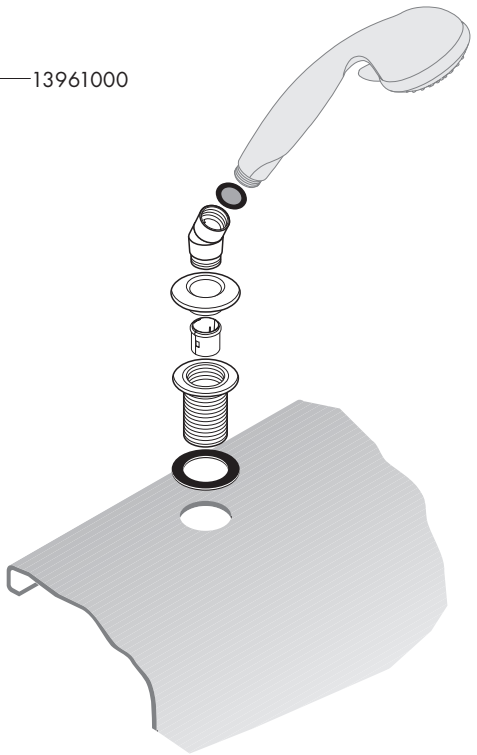
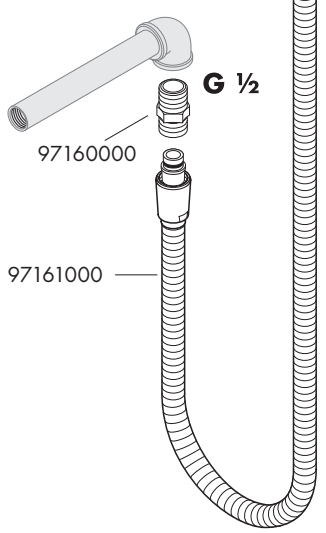
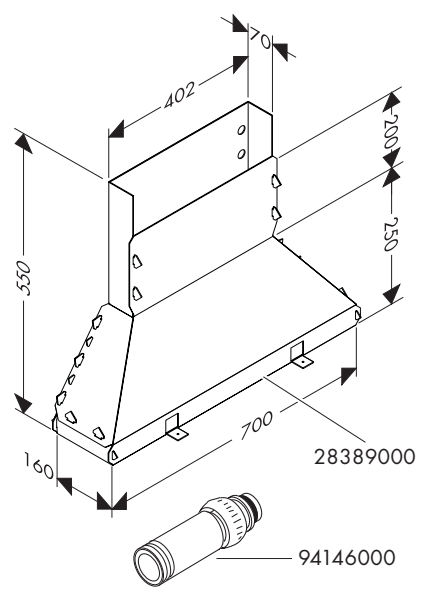
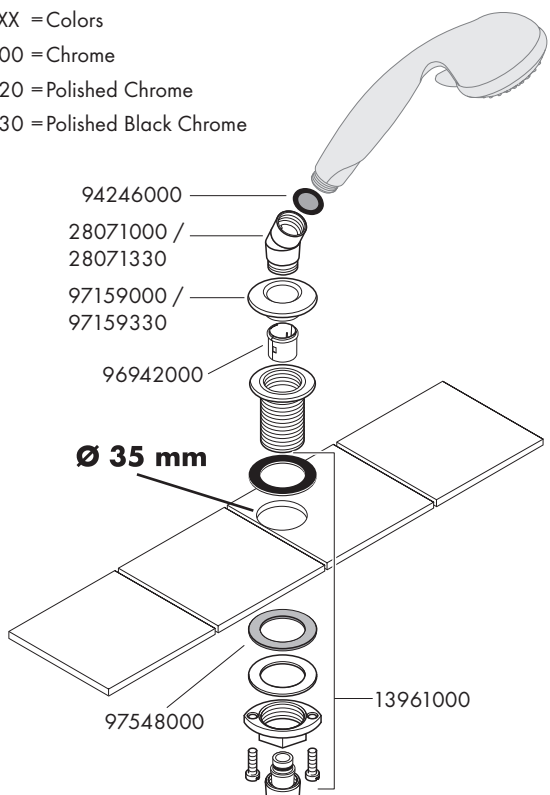



- DE** Reinigungsempfehlung / Garantie / Kontakt
- FR** Recommandation pour le nettoyage / Garanties / Contact
- EN** Cleaning recommendation / Warranty / Contact
- IT** Raccomandazione di pulizia / Garanzia / Contatto
- ES** Recomendaciones para la limpieza / Garantía / Contacto
- NL** Aanbevelingen inzake reiniging / Garantie / Contact
- DK** Rensning, anbefaling / Garanti / Kontakt
- PT** Recomendações de limpeza / Garantia / Contacto
- PL** Zalecenie dotyczące pielęgnacji / Gwarancja / Kontakt
- CS** Doporučení k čištění / Záruka / Kontakt
- SK** Odporúčania pre čistenie / Záruka / Kontakt
- ZH** 清洁指南 / 担保 / 接触
- RU** Рекомендации по очистке / Гарантия / Контакты
- HU** Tisztítási tanácsok / Garancia / érintkezés
- FI** Puhdistussuositus / Takuu / Kosketus
- SV** Rengöringsrekommendationer / Garanti / Contacto
- LT** Valymo rekomendacijos / Garantija / Kontaktai
- HR** Preporuke za čišćenje / Garancija / Kontakt
- TR** Temizleme önerisi / Garanti / Temas
- RO** Recomandări pentru curățare / Garanție / Contact
- EL** Σύσταση καθαρισμού / Εγγύηση / επαφή
- SL** Priporočilo za čiščenje / Garancija / Kontakt
- ET** Puhastussooitused / Garantii / Kontakt
- LV** Tīrīšanas ieteikumi / Garantija / Kontakti
- SR** Preporuke za čišćenje / Garancija / Kontakt
- NO** Anbefaling for rengjøring / Garanti / Kontakt
- BG** Препоръка за почистване / Гаранция / Контакт
- SQ** Këshilla rreth pastrimit / Garancia / Kontakt
- KO** 세정시 권장사항 / 품질보증 / 접촉
- AR** توصيات التنظيف / الضمان (الولايات المتحدة الأمريكية) / اتصال



[www.hansgrohe.com/
cleaning-recommendation](http://www.hansgrohe.com/cleaning-recommendation)



[www.hansgrohe.com/
cleaning-recommendation](http://www.hansgrohe.com/cleaning-recommendation)



[www.hansgrohe.com/
cleaning-recommendation](http://www.hansgrohe.com/cleaning-recommendation)



[www.hansgrohe.com/
cleaning-recommendation](http://www.hansgrohe.com/cleaning-recommendation)